

Monaframe Doors

Sliding (Patio) Door System

The Monaframe Sliding Door System creates 2, 3 or 4-panel combinations of sliding doors and fixed lights. Adaptors facilitate the direct connection of 75mm profile Monaframe windows and other systems to the 96mm profile heads or jambs of sliding doors, providing the specifier with an unrivalled choice of truly co-ordinated fenestration options. The system meets security criteria, is fully weatherstripped and all component profiles incorporate thermal barriers.

Monarch is a product range from Sapa Building Systems; its systems are fabricated and installed through a nationwide network of specialists. Monarch systems have been used successfully on many commercial and residential projects.



ADVANTAGES

- *Versatile and comprehensive - creates sliding door assemblies up to 6000mm overall width and 2460mm overall height*
- *High security - and safety - designed into system and hardware options*
- *Monalock® multi-point locking system*
- *Virtually maintenance-free*
- *Wide choice of colour finishes*
- *Monaframe compatible*

OPTIONS

- *Trickle ventilators to meet Building Regulations needs*
- *4mm to 6.4mm single glazing or 20mm to 26mm double glazing units*
- *Mid-rails or spandrel panels can be incorporated*

APPLICATIONS

Versatile and comprehensive, the Monaframe Sliding Door System has a wide range of applications:

- New-build or refurbishment projects
- Retail, commercial or domestic schemes
- Incorporated, as a single component, into structural openings, or
- Combined with other Monaframe window or fixed light assemblies at the sides or head.

The system includes the Monalock® multi-point security locking system.

STANDARDS AND QUALITY CONTROL

Sapa's quality control procedures have been approved under BS EN ISO 9001. Sapa is a member of the Glass and Glazing Federation and the Council for Aluminium in Building.

The Monaframe Sliding Door System has been independently tested to BS 5286 exceeding the weather performance criteria.

The precise weather performance of assemblies of doors, windows and fixed glazing will, of course, depend on the door (or window) types actually incorporated.

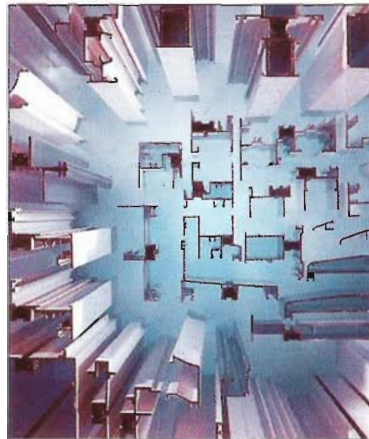

THE MONAFRAME SYSTEM

The Monaframe System is a comprehensive suite of thermally broken aluminium sections, 75mm in depth, which has been designed and developed not only to be configured into individual window, door, roof glazing and facade glazing applications, but also to be fully co-ordinated one with another.



Specifiers have complete freedom to evolve fenestration designs with the confidence that adjacent elements will correctly and neatly couple together.

Monaframe Sliding Doors are an integrated part of the Monaframe System, fully compatible with other components and assemblies.

COMPOSITION

Extruded aluminium to BS 1474: 1987, specification 6063 T6 with a high strength 2-part polyurethane resin thermal barrier.

Aluminium has been tried and tested over many years in building projects, has a known long life and is inherently durable when used in building situations exposed to temperature differences, moisture and sunlight.

COMPONENTS

Because of aluminium's inherent strength advantages, Monaframe profiles and assemblies are slim and neat in appearance.

Unlike some other materials no additional reinforcement is needed on structural elements.

Outer Framing Elements

Outer frames (directly fixed into openings) use 96mm deep profiles at head and jambs. At the foot a combined track and cill profile, 162mm deep, is used.

Trickle ventilation is provided through the head frame, with an outer 'hood' profile, integral flyscreen and a draughtstripped inner flap.

The use of adaptor A776 enables the direct integration of necessarily deeper profile Monaframe sliding door assemblies into the extensive 75mm deep profile Monaframe system of doors and windows at head or jamb (as 'flag' windows).

In some circumstances specifiers may wish to incorporate thermally insulated sliding doors into full height Monaframe glazed screens, windows and facades, with a continuous cill profile under all elements. In this situation, use the Monarch Thermal Break Sliding Door with adaptors CKA12, CKA13, CKA14 (plus CKM17 as required) and with cill profile A993 below both the door and side panels.



Sliding and Fixed Panels

Sliding Door assemblies consist of 2, 3 or 4 panels in the following combinations:

- Fixed - Sliding (L or R)
- Fixed - Sliding (L or R) - Fixed
- Fixed - Sliding - Sliding - Fixed

Other configurations are available to special order.

Fixed panels are positioned to the 'inside' and sliding to the 'outside' within the outer frame.

Various door or fixed panel stiles and mullions are used to suit these combinations, including interlock (passing), meeting and lock profiles.

For other sizes or configurations refer to Monarch.

Sliding doors use stainless steel tracks and tandem rollers.

Mid-rails and Spandrels

Sliding, or fixed, panels can incorporate:

- 110mm high 'flat profile' mid-rail or
- 124mm high 'recessed profile' mid-rail (suitable for letterplates) or
- Spandrel in obscured or patterned glass or as a solid/insulated sandwich panel.

Construction

Perimeter framing elements are butt jointed and screwed, incorporating silicone sealants. Door leaves are mechanically butt jointed, with the rails being positively located into vertical members.

Cover Trims

A comprehensive range of colour coated cover trim options is available, of various sizes, and in convex, concave, angled and flat profiles.



Sliding Doors

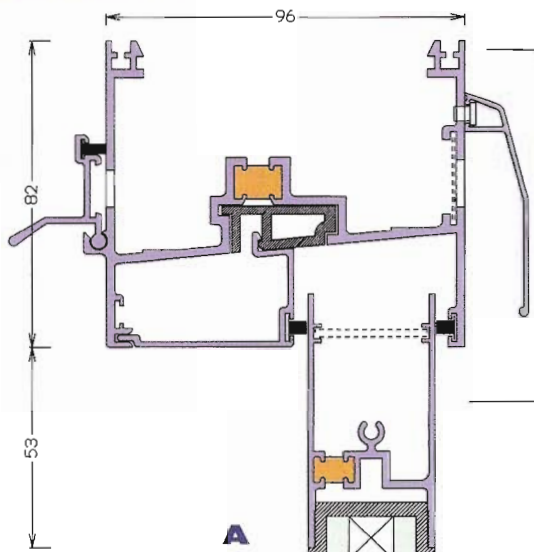

Monaframe Sliding Door head frame profile with trickle vent - hood and flyscreen to external face and binged flap to inside

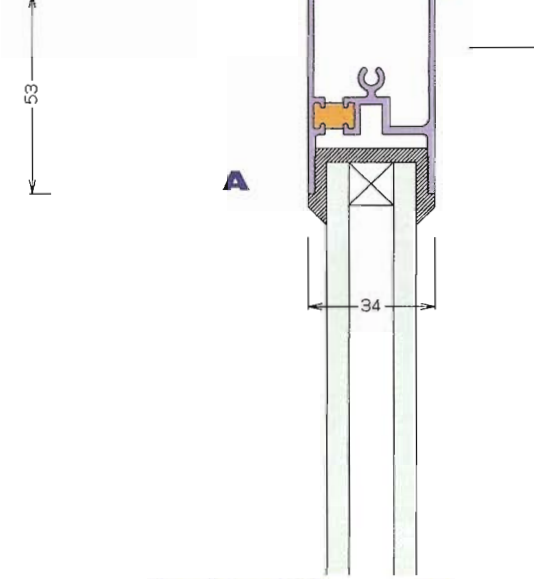

Monaframe Sliding Door top rail profile

Vertical Section

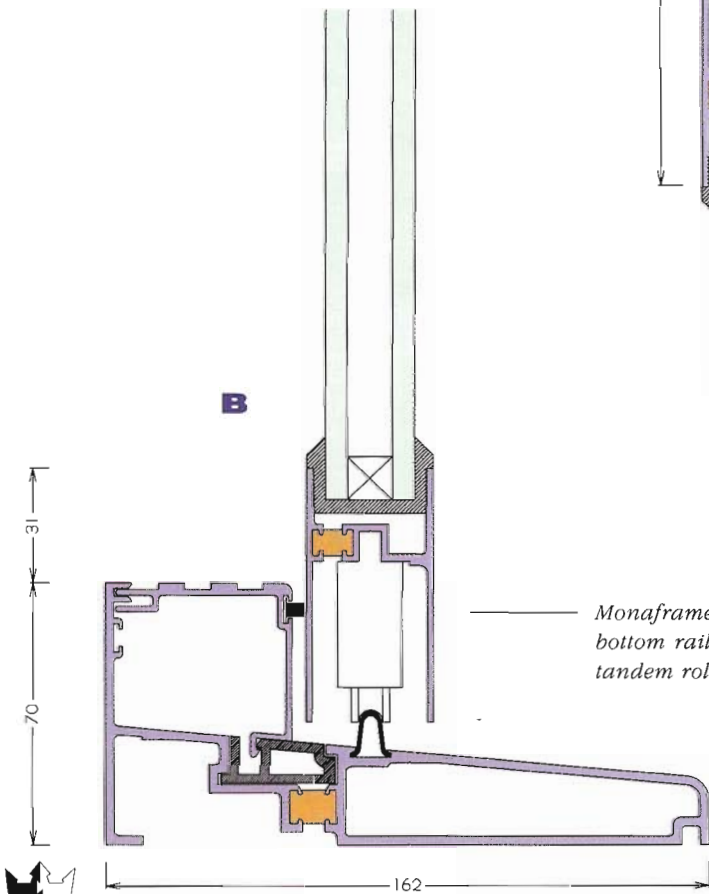

Monaframe Sliding Door bottom rail profile with tandem rollers

Monaframe Sliding Door cill frame profile with stainless steel track and threshold inserts

Mid-Rails and Spandrel

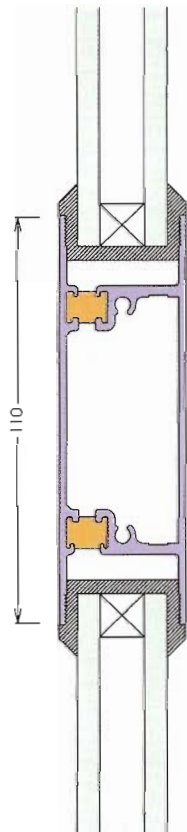

Flat profile mid-rail

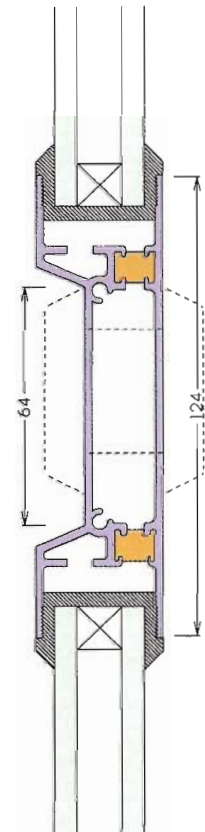

Recessed profile mid-rail - letterplate shown with broken line -

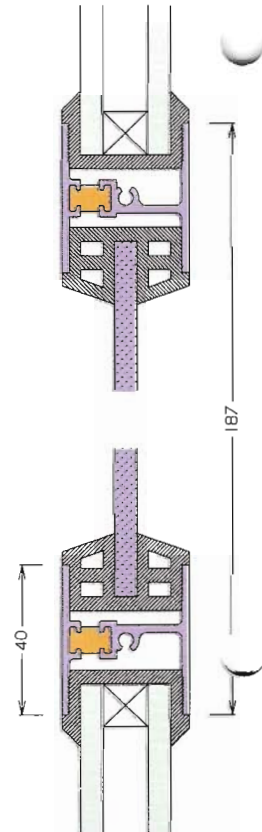

*Spandrel assembly
As noted, Monarch standard spandrel is 187mm high.
It can be sized to suit requirements.*

Horizontal Section - Two Panel Assembly

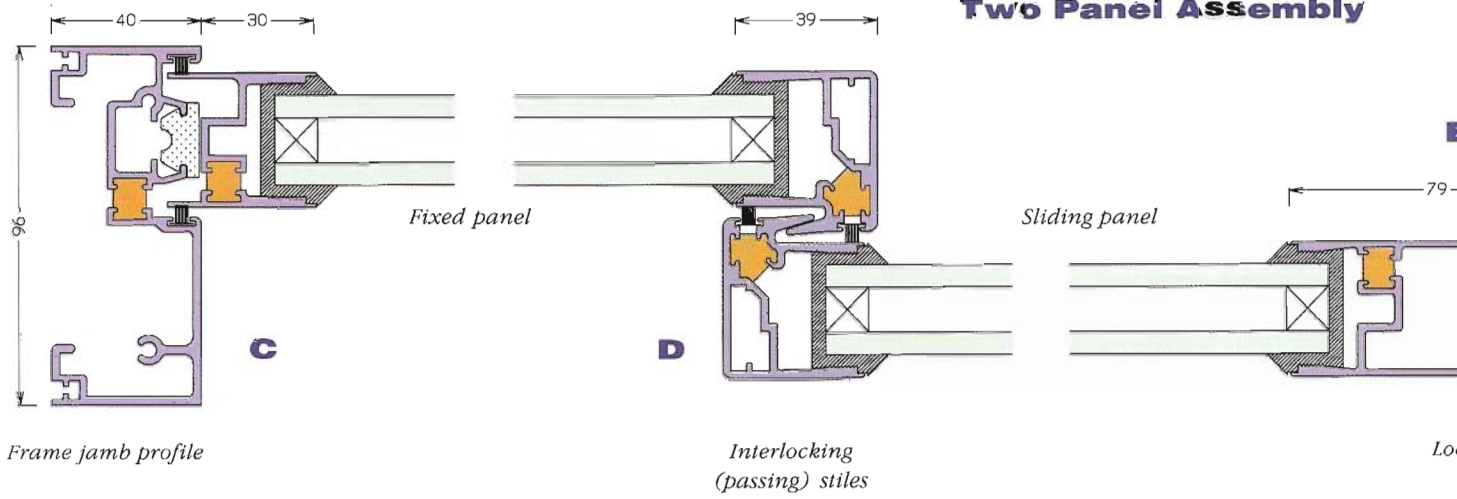

Frame jamb profile

Interlocking (passing) stiles

Horizontal Section - Three Panel Assembly

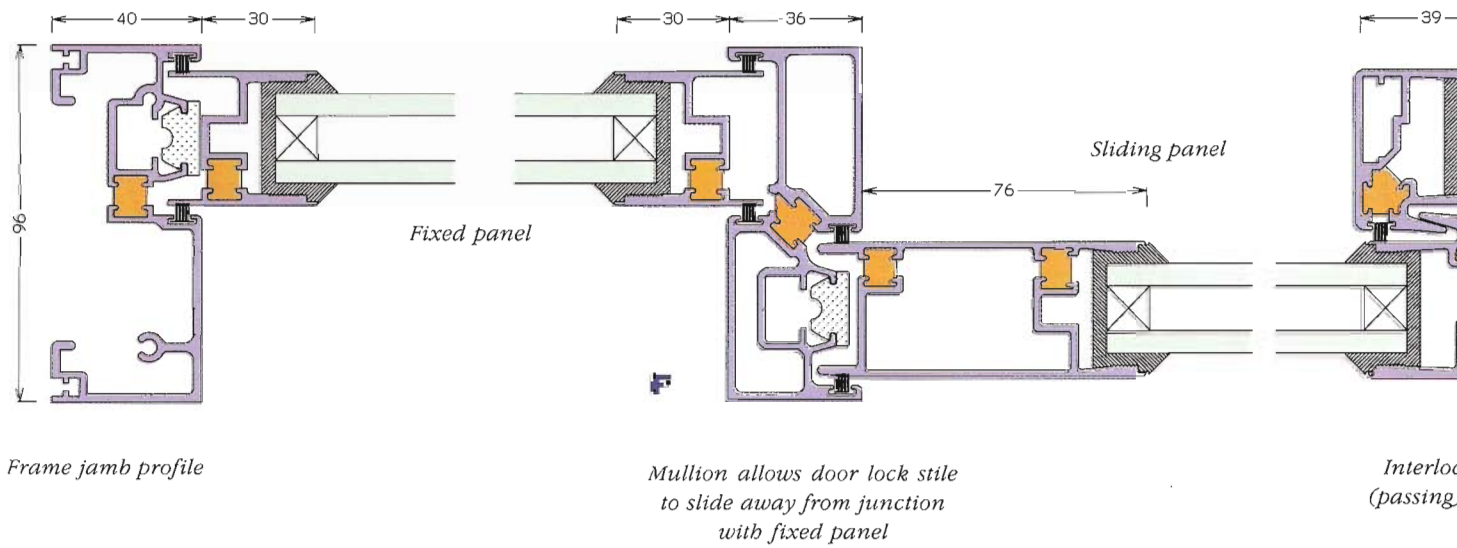

Frame jamb profile

Mullion allows door lock stile to slide away from junction with fixed panel

Interlocking (passing)

Horizontal Section - Four Panel Assembly

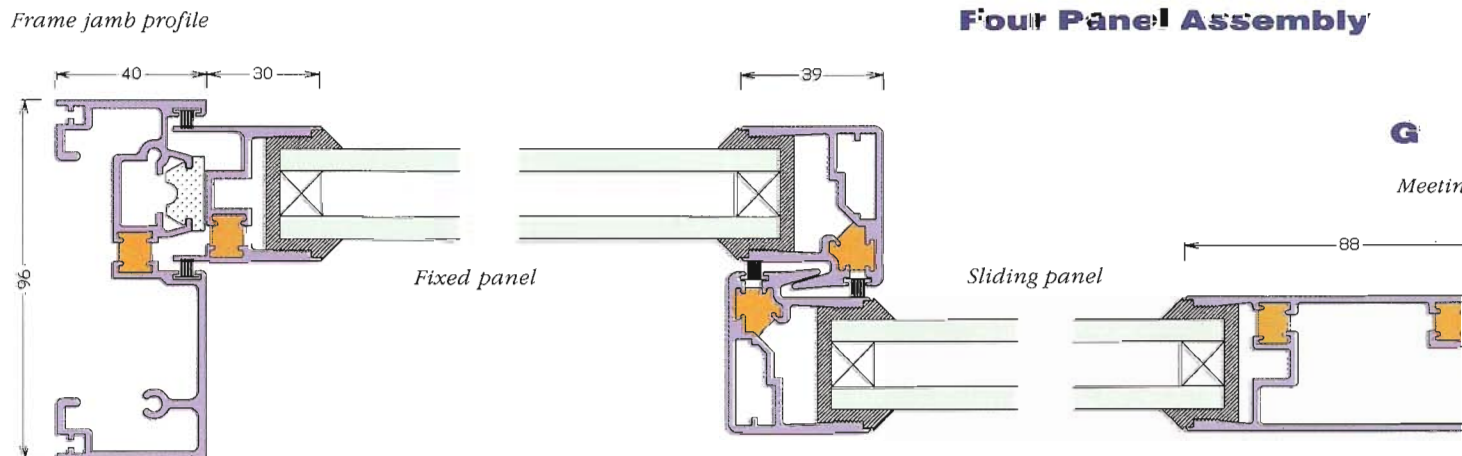

Frame jamb profile

Meeting



Sliding Doors

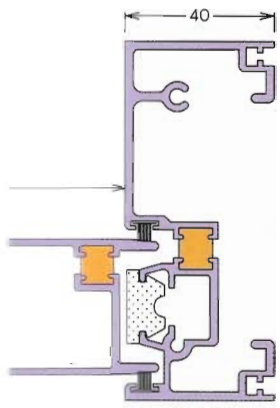

locking stile

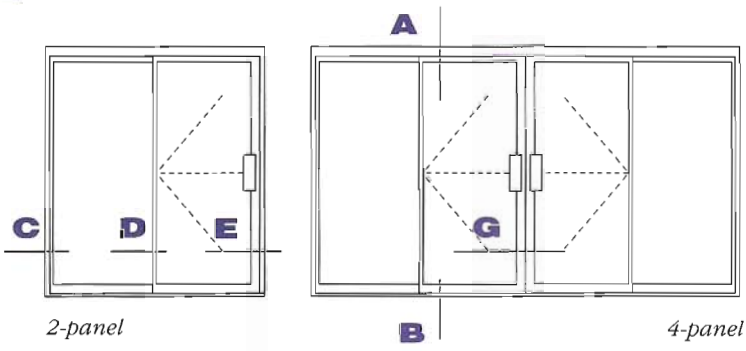

Key Elevations

2-panel

4-panel

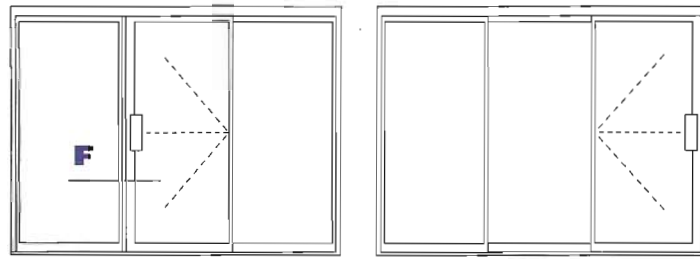

3-panel

Adaptor A776

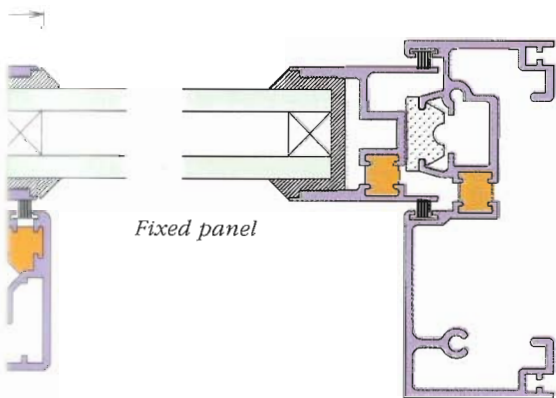

Fixed panel

locking stiles

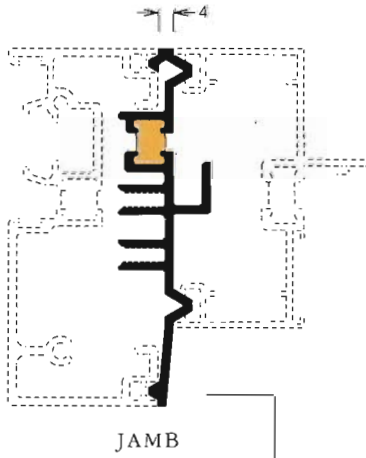

JAMB

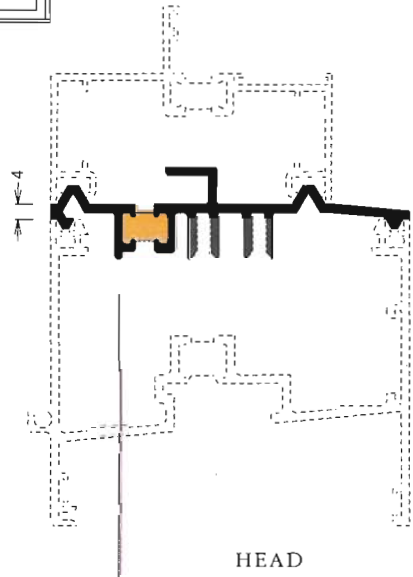

HEAD

Adaptor A776 links Monafame Sliding Door frames with other (75mm) Monafame profiles at jambs or head

Interlocking (passing) stiles

locking stiles

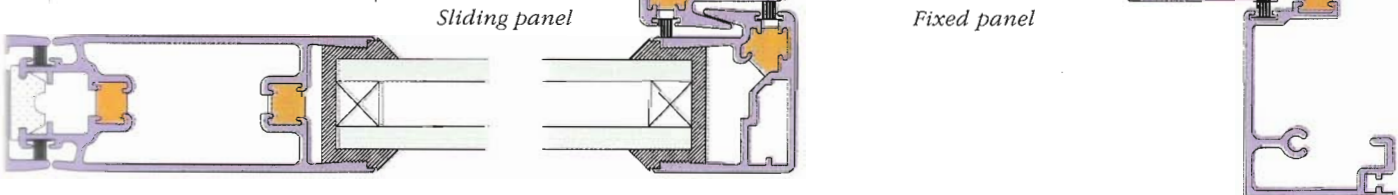
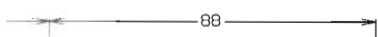

Sliding panel

Fixed panel



Sliding (Patio) Doors

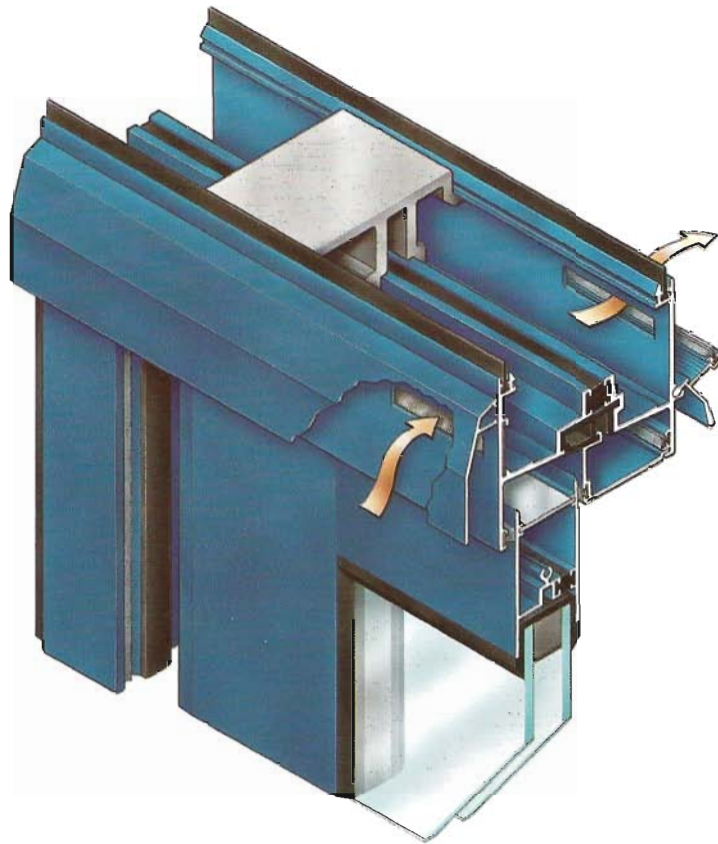

LIMITATIONS

Monaframe Sliding Doors can be manufactured to any size from the following standard kits:

Two panel assemblies -
3230mm maximum width,
2460mm maximum height

Three panel assemblies -
4520mm maximum width,
2460mm maximum height

Four panel assemblies -
6000mm maximum width,
2460mm maximum height

For other sizes or configurations refer to Sapa.

GLAZING

The system can be glazed with single glass (4mm to 6.4mm) or double glazing units, to BS 6262. Double glazing or other glass thicknesses accommodated are from 20 to 26mm.

A suite of wrap-around synthetic rubber sealing gaskets (black or white) is available to accommodate this range of thicknesses.

Thermal insulation, impact safety and security considerations will normally dictate the use of laminated or toughened sealed double glazing units.

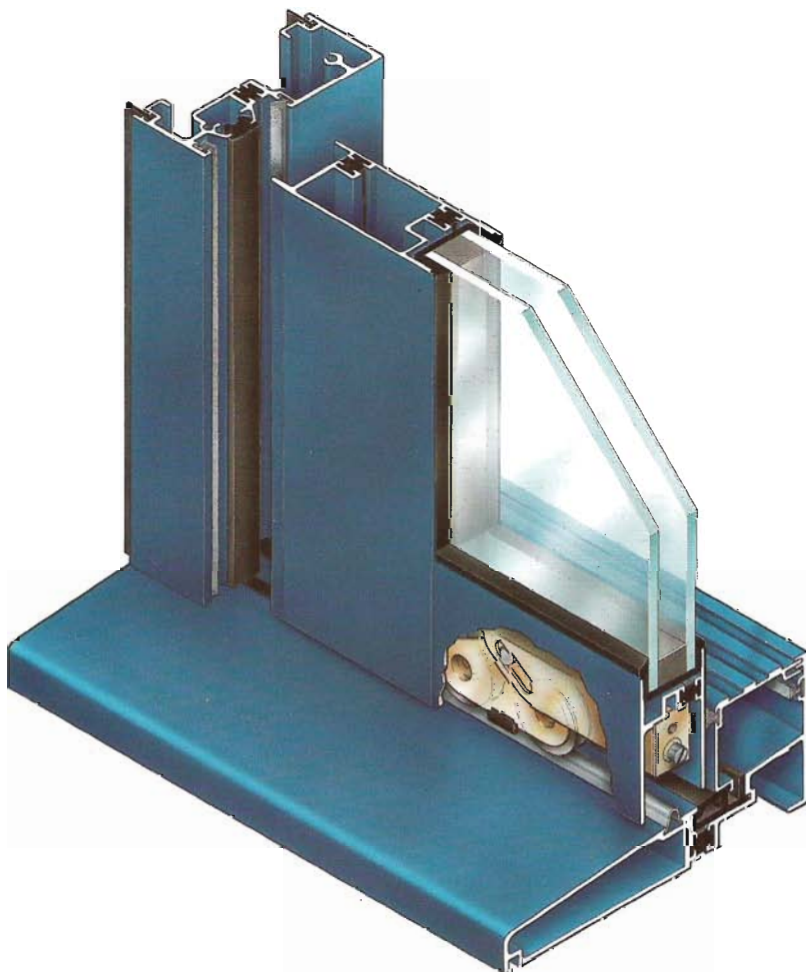



Sliding (Patio) Doors

OPERATION AND FITTINGS

Monaframe Sliding Doors run smoothly using stainless steel tracks and tandem stainless steel rollers. Closing points incorporate resilient buffers.

Ease of use, combined with high security, has been a major objective in developing the Monaframe Sliding Door System.

SECURITY AND SAFETY

The Monaframe Sliding Door System offers particular security and safety related features.

All doors are fitted with a Monalock® security system which locks the door in at least four places.

An operating lever (fitted internally or internally and externally) throws four widely spaced mushroom headed stainless steel bolts into a full-length stainless steel keep. The sliding panel cannot be forced open and adjustments eliminate free play when in the locked position. The levers are designed to fracture if excessive force is applied when deadlocked into position.

Additionally, on 2 and 3 panel assemblies, a central hook bolt may also be incorporated, with a shoot bolt which can hold the door in a partially open, child-safe, position.

The 5-pin cylinder lock used can be suited or master keyed, operated from inside or outside, and an anti-drill pin version meets Association of British Insurers requirements. Blanking plates prevent access to fixing screws and anti-lift blocks prevent the door being lifted out of the perimeter frame.

ENVIRONMENTAL PERFORMANCE

Thermal Insulation and Condensation Control

All relevant Monaframe Sliding Door aluminium sections are thermally broken using a high strength 2-part polyurethane resin barrier between internal and external components.

The absence of cold bridges inhibits condensation formation on door frames. All head assemblies neatly incorporate a trickle vent complying with 1995 standard Building Regulations (Part F) requirements for background ventilation.

Weather Performance

The Monaframe Sliding Door System has been independently tested to BS 5286. The system exceeds the weather performance criteria achieving the following:

Air Permeability	-	300 Pa
Water Penetration	-	300 Pa
Gust Deflection	-	1000 Pa

Assemblies include high quality resilient closing seals and gaskets to ensure full weatherstripping.

A flexible perimeter 'flipper' section is available to provide a background for mastic pointing and to accommodate structural opening variations.

APPEARANCE

Aluminium profiles are polyester powder coated to BS 6496: 1991. Application, using the Syntha Pulvin or Interpon processes, is stringently quality controlled. Full gloss white (RAL 9910) and semi-gloss dark brown (BS 08B29) are available as standard.

Alternatively, to order, profiles can be supplied in a comprehensive range of 389 RAL, BS and metallic colour options, including matt, satin or gloss finishes. Anodised finishes can also be supplied.

Please refer to separate Sapa publications for further details.

Colour cards and samples are available.

MAINTENANCE

At the time of installation the operating fittings are thoroughly cleaned and lightly lubricated with vaseline, silicone lubricant or acid free oil. It is recommended that this action is repeated at least annually to ensure satisfactory operation. The finished appearance of Monaframe Sliding Doors is easily maintained through regular cleaning.

SPECIFICATION

The use of the National Building Specification is recommended, parts L2- (Doors) and L1-710 (Protection of Components).

Sapa's policy is one of continual system development and we reserve the right to incorporate design improvements and changes. All details were correct at time of publication.

Detailed advice, backup and up-to-date information, on all systems and products and their applications, is freely available from: